

LTO Server **LTS-90**



LTO server equipped with an LTO-9 drive. Store up to 18 TB of video and audio media on LTO-8/9 tapes when used in uncompressed mode. Fast maximum transfer of 300 MB/s (2.4 Gbps), using an optional high-speed interface. Enables high-capacity 4K archiving and backup.

Comprehensive file backup/archiving

- A single LTS-90 unit with a 20 TB storage option is all you need for primary and secondary backup.
- Ready for files of all types and formats.
- Use as a compact server to archive video files, back up NLE project files, and store still images, documents, and other critical data.
- Back up to/read from LTO tape via Ethernet or USB.

Automatic proxy video generation while archiving

- Tags video files with metadata when archiving, and writes to formats compatible with LTR series video archiving recorders.
- Optional automatic thumbnail and proxy video generation (low to HD resolution*1, with multi-codec support*2) are available.
- Use partial retrieval to extract required portions of video files on LTO tape as separate files.

Versatile data backup

- Read or write files to LTO tape via FTP from computers on the same local network as the LTS-90.
- Also enables folder-based archiving of video files on devices connected to the LTS-90 via USB.
- Fast data backup capability to LTO tape from external devices (USB 3.0 devices or NAS).
- Data can be backed up to LTO tape and an attached USB HDD or NAS simultaneously, and copies can be verified after backup.

MAM function (Optional)

- MAM function (LTS-MAM) can be installed into the unit.
- Access assets via a web browser from a LAN-connected PC. Manage clips and their thumbnails or proxy video, metadata, or any other information in the LTS-MAM database.
- Assets can be saved with related data as an attached file.

Backup and migration support

External LTO Drive Unit LTO-EU8

- Adding dedicated, optional software (LTS-MGS) enables time-saving LTO to LTO data copying without using HDDs.
- Supports LTO-7 tape media, which is incompatible with an LTO-9 drive.

Options to support backup and migration

- LTS-I-CP: Installed on a computer connected via Ethernet to 2 LTR/LTS units, enables LTO tape files to be copied from either unit.
- LTO migration tool: Software that unifies multiple LTO-5/6 tapes archived by LTR/LTS to LTO-7/8 tapes.

Interface for high-speed transfer (Optional)

10 GbE supported options

- LTS-10GR (RJ45 connector model)
- LTS-10GS (SFP+ connector model)

*1 HD resolution is available for LTS-SX, LTS-XAVC, and LTS-XAVC-L MP4 proxy files. *2 Optional.

LTS-90 Datasheet

1. Specifications

Basic specifications

Temperature	10°C to 35°C
Humidity	20% to 80% (no condensation)
Power	AC 100 V to 240 V \pm 10%, 50/60 Hz
Consumption	AC 100 V to 120 V: 130 VA (128 W) AC 220 V to 240 V: 154 VA (127 W)
Dimensions	212 (W) x 116 (H) x 422.5 (D) mm
Weight	8 kg
Consumables (at 24-hour operation)	Cooling fan: Replace every 3 years. Power: Replace every 5 years. Battery: Replace every 5 years. (*) Hard disk: Replace every 5 years.

* Yearly battery replacement is recommended when unit is stored without powering on for long periods

Technical specifications

Removable Storage	LTO-8/ LTO-9 (File system: IBM LTFS)
Internal Storage	8TB HDD 20TB HDD (with optional LTS-90HDD20T installed)
Interfaces	
USB	USB3.0 series A connector x 4 (front x 2, rear x 2)
LAN1/2	100BASE-TX/1000BASE-T, RJ-45 x 2
To External Drive	Mini-SAS HD(SFF-8644) Connector x 1 To connect to an LTO-EU7/ LTO-EU8, an external LTO-7 drive made by IBM or an auto loader made by IBM. (LTS-TSC optional software is required to connect to an auto loader.)
VGA	15-pin D-Sub (female) x 1
RS-232C	Not used
IPMI	Not used

LTO-8 Basic Performance

Cartridge Size	105 (W) x 22 (H) x 102 (D) mm
Capacity	Approx. 12.0 TB (data area: 11711 GB / 10907 GiB)
Recording capacity	The followings, values excluding ancillary data and proxy video files, are theoretical. Actual values may differ depending on LTO tape and head conditions.
CBR/4:2:2/422P@HL	Approx. 380 hours (50 Mbps, HD)
VBR/4:2:0/MP@HL	Approx. 570 hours (35 Mbps, HD)
Response	File system information acquisition time: under one minute in typical case. File seek time: within three minutes (This will take more time in some cases.)

LTO-9 Basic Performance

Cartridge Size	105 (W) x 22 (H) x 102 (D) mm
Capacity	Approx. 18.0 TB (data area: 16736 GB / 16344 GiB)
Recording capacity	The followings, values excluding ancillary data and proxy video files, are theoretical. Actual values may differ depending on LTO tape and head conditions.
MPEG-2 422@HL	Approx. 576 hours (50 Mbps, HD)
MPEG-2 MP@HL	Approx. 876 hours (50 Mbps, HD)
Response	File system information acquisition time: under one minute in typical case. File body seek time: within three minutes (This will take more time in some cases.)
Media Initialization (Optimization)	New LTO-9 tapes require initialization the first time they are inserted; this is a one-time operation and is not required thereafter. It is performed automatically when a tape is inserted. Initialization can be performed on any drive, and the initialized tape can be used without modification on another drive. The average media initialization time is about 40 minutes. Most initializations take less than 60 minutes, but can take up to 2 hours. During initialization, the Single Character Display shows a lower case c and the green LED blinks.

H.264 file

Video	Resolution Low *	Compression format	H.264 Baseline Profile Level 2.1
		Resolution	HD: 424 x 240 SD: 320 x 240 (NTSC) 384 x 288 (PAL)
		Frame rate	NTSC family: 29.97fps, PAL family: 25 fps
		Bitrate	900 kbps
	Resolution Normal *	Compression format	H.264 Main Profile Level 3.2
		Resolution	HD: 1280 x 720
		Frame rate	NTSC: 29.97 fps, PAL: 25 fps
		Bitrate	2000 kbps
	Resolution High *	Compression format	H.264 High Profile Level 4.0
		Resolution	HD: 1920 x 1080
		Frame rate	NTSC: 29.97 fps, PAL: 25 fps

		Bitrate	4000 kbps
Audio	Resolution Low *	Compression format	AAC LC
		Number of channels	2 ch
		Sampling rate	48 kHz 16 bit
		Bitrate	96 kbps
	Resolution Normal High *	Compression format	AAC LC
		Number of channels	2 ch
		Sampling rate	48 kHz 16 bit
		Bitrate	384 kbps
File format		Container format	MP4
		Bitrate	Auto-calculated from video and audio bitrates
Timecode		-Added to each frame as the Picture Timing SEI message in H.264 streams. -Timecode can be added to the video content by changing setting.	

* Changing the resolution requires the corresponding codec option. (LTS-SX, LTS-XAVC or LTS-XAVC-L)

Windows Media File

Video	Compression format	Windows Media Video V9	
	Resolution	HD: 424 x 240 SD: 320 x 240 (NTSC) 384 x 288 (PAL)	
	Frame rate	NTSC family: 29.97 fps, PAL family: 25 fps	
	Bitrate	1,300 kbps	
Audio	Compression format	Windows Media Audio V9	
	Number of channels	2 ch	
	Sampling rate	48 kHz	
	Bitrate	192 kbps	
File format		Container format	WMV (ASF)
		Bitrate	Auto-calculated from video and audio bitrates
Timecode		-Timecode can be added to the video content by changing setting.	

Options

LTR-BWIN ^(*)	LTR Browser (Windows Version)
LTR-BMAC ^(*)	LTR Browser (Mac Version)
LTS-SX	MPEG-2 (OP-1a) Plugin
LTS-PAD	AVC-Intra/DVCPRO Plugin
LTS-PRS	ProRes422 Plugin
LTS-DNxHD	DNxHD Plugin
LTS-XAVC	XAVC Plugin

LTS-XAVC-L	XAVC Long Plugin
LTS-AVCHD	AVCHD Plugin
LTS-MAM ^(*3)	Media Asset Manager
LTS-TSC	LTO Auto-loader Plugin
LTS-MGS ^(*2)	LTS Migrator (Windows Version)
LTS-10GR ^(*2)	10GbE option (RJ45 model)
LTS-10GS ^(*2)	10GbE option (SFP+ model) 10GBASE-SR SFP+ Optical Transceiver
LTO-EU7/8 ^(*1)	LTO-7/8 external unit
LTS-90HDD20T	20TB HDD Option
<p>^(*1) User Manual (PDF) is included in each CD-ROM.</p> <p>^(*2) Download User Manual (PDF) from LTS-90 page on the FOR-A website.</p> <p>^(*3) Download User Manual (PDF) from LTS-MAM page on the FOR-A website.</p>	

Accessories

AC Cord, LTO Cleaning cartridge, SFP+ optical transceiver (Included only when LTS-10GS is installed),
Packing list

2. External Dimensions

(All dimensions in mm.)

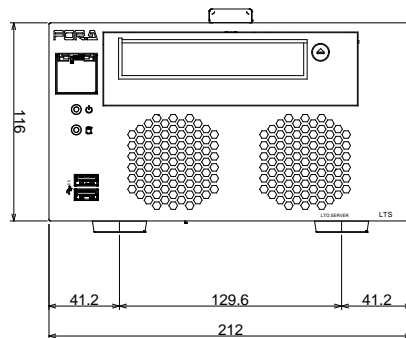
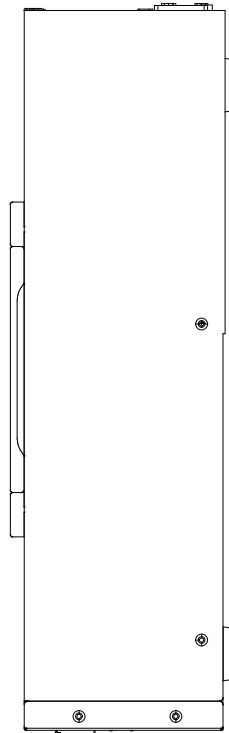
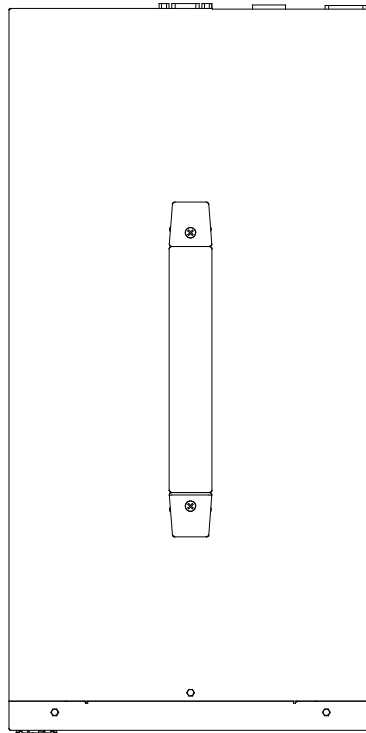
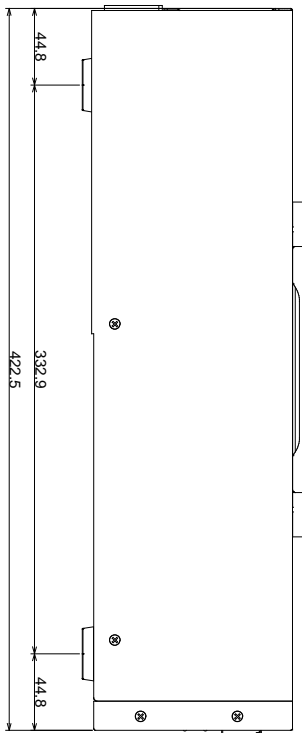
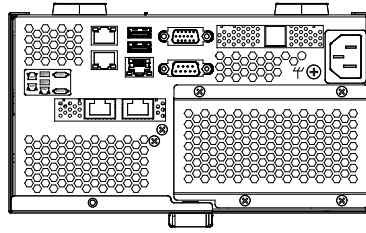



FOR-A COMPANY LIMITED www.for-a.com

ISO 9001 and 14001 certified
(Sakura R&D)

Head Office:

3-8-1 Ebisu, Shibuya-ku, Tokyo 150-0013, Japan
Tel: +81 (0)3-3446-3936

**FOR-A Corporation of America
Corporate Office/Service Center:**

11155 Knott Ave., Suite G, H & I, Cypress, CA 90630, U.S.A.
Tel: +1 714-894-3311

FOR-A Corporation of America Northeast Office:

Tel: +1 973-220-8471

FOR-A Corporation of America Southeast Office:

Tel: +1 305-773-7608

FOR-A Corporation of America Support Center:

2400 N.E. Waldo Road, Gainesville, FL 32609, U.S.A.
Tel: +1 352-262-5779

FOR-A Latin America and the Caribbean Miami Office:

Tel: +1 657-600-5759

FOR-A Latin America and the Caribbean Sao Paulo Office:

Tel: +55 11-99913-3751

FOR-A Latin America and the Caribbean Mexico City Office:

Tel: +52-55-5072-4969

FOR-A Europe S.r.l.:

Via Volturmo, 37, 20861 Brugherio MB, Italy
Tel: +39 (0)39-916-4811

FOR-A UK Limited:

Trident Court, 1 Oakcroft Road, Chessington, KT9 1BD, UK
Tel: +44 (0)20-3044-2935

FOR-A Italia S.r.l.:

Via Volturmo, 37, 20861, Brugherio MB, Italy
Tel: +39 (0)39-881-086

FOR-A Corporation of Korea:

1007, 57-5, Yangsan-ro, Yeongdeungpo-gu, Seoul 07271, Korea
Tel: +82 (0)2-2637-0761

FOR-A China Limited:

1618A Huateng Building, No. 302, 3 District, Jinsong, Chaoyang,
Beijing 100021, China
Tel: +86 (0)10-8721-6023

FOR-A Middle East-Africa Office:

DSC Tower, Office 207, Dubai Studio City,
P.O. Box 502688, Dubai, UAE
Tel: +971 (0)4-551-5830

FOR-A India Private Limited Corporate Office:

Unit No: 800, World Trade Tower, Sector-16, Noida-201301, Uttar
Pradesh, India
Tel: +91-120-4238674 / +91-120-4252330

FOR-A India Private Limited Mumbai Office:

202-203, Wellington Business Park No-01, Marol, Off, Andheri Kurla
Road, Andheri East, Mumbai-400059, Maharashtra, India
Tel: +91 22-49795570

FOR-A South East Asia Hong Kong Office:

Studio 09, Rm. A1, 3/F., Phase 1, Hang Fung Ind. Bldg., 2G Hok
Yuen St., Hung Hom, Hong Kong
Tel: +852-2110-9227

FOR-A South East Asia Singapore Office:

Tel: +65-8686-8086