

INSTALLATION GUIDE

HVS-100PSM

Redundant Power Supply for MU

2nd Edition

Upon Receipt

Unpacking

HVS-100PSM cards and their accessories are fully inspected and adjusted prior to shipment. Operation can be performed immediately upon completing all required connections and operational settings.

Check your received items against the packing lists below. Check to ensure no damage has occurred during shipment. If damage has occurred, or items are missing, inform your supplier immediately.

ITEM	QTY	REMARKS
HVS-100PSM	1	Redundant power supply unit for HVS-100
Power cord	1 set	Used to connect to an AC power source. Cord retaining clip included
Cable A	1	Used to connect to DC power output. (yellow/black, yellow/black and black/brown wires)
Cable B	1	Used to connect to the other power supply unit. (orange/brown wires)
Cable C	1	Used to connect to power switch assembly. (red/violet wires) Ground cable (black) attached
Insulation sheet	1	
Binding screws (Large)	4	Used to secure two Cable A connectors (black).
W-sems screws	4	Used to attach HVS-100PSM to Power Supply tray.
Binding screw with normal and toothed washers	1 set	Used to secure Cable C ground cable.
Cable tie	2	Used to hold and fix Cable A and C wires.
Product Label	1	Displays unit serial number.
Installation Guide	1	This Guide Book

Table of Contents

1. Prior to Starting	5
2. Installing the HVS-100PSM.....	5
2-1. Removing the Power Supply Tray.....	5
2-2. Installing the HVS-100PSM.....	5
2-3. Connecting Cables.....	6
2-3-1. Installing Cable A	7
2-3-2. Installing Cable B.....	8
2-3-3. Fixing Cables	8
2-3-4. Installing Cable C.....	9
2-4. Re-inserting the Power Supply Tray	9
3. Checking Operation	10
3-1. Power ON	10
3-2. Checking the Status Menu.....	10
3-3. Affixing the Supplied Label	10

1. Prior to Starting

The HVS-100PSM is a power supply unit specially designed for the HVS-100 switcher. Each switcher comes with two power supply slots with a single power supply unit installed. This optional HVS-100PSM power supply unit allows you to operate an HVS-100 continuously, even if one power supply unit fails.

The HVS-100PSM can be also used to replace a standard power supply unit.

 <p>CAUTION</p>	<p>Installing this option requires the unit interior to be accessed by opening the panel. Installation should only be performed by qualified technical personnel. The power should be turned OFF and all unit power cords disconnected before this installation is performed.</p>
---	---

2. Installing the HVS-100PSM

2-1. Removing the Power Supply Tray

- (1) Remove the 4 (middle size) binding screws on the HVS-100 rear panel.
- (2) Grab the two handles on the power supply tray and pull straight out to remove the tray from the chassis.

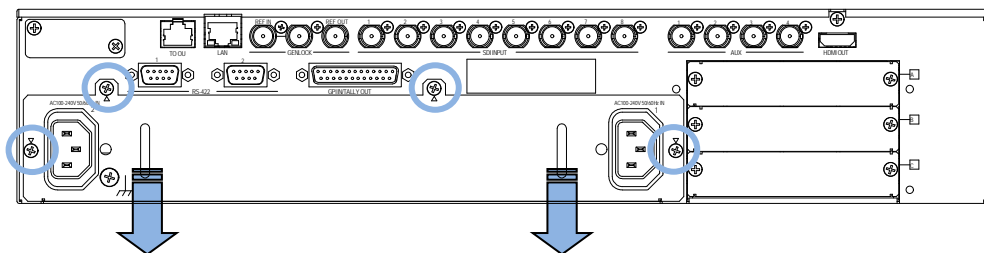

2-2. Installing the HVS-100PSM

- (1) Unpack the HVS-100PSM.
- (2) Place the supplied insulation sheet on the tray as shown in the figure below.

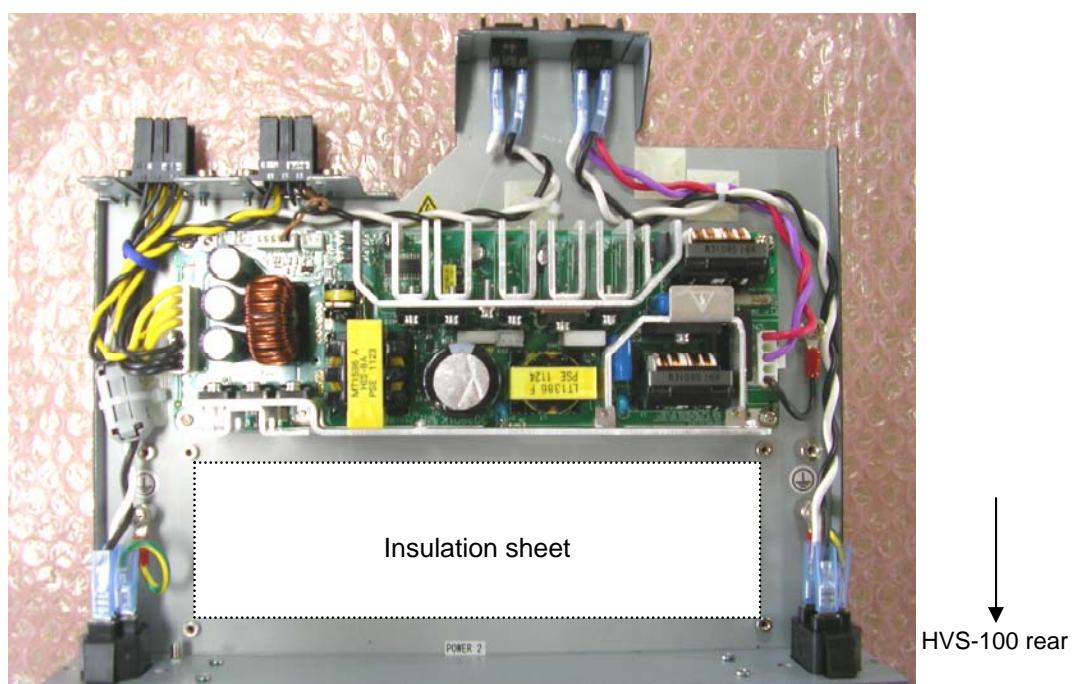

- (3) Place the power supply unit (HVS-100PSM) on the insulation sheet.
- (4) Secure the power supply unit to the tray using the four supplied W-sems screws.

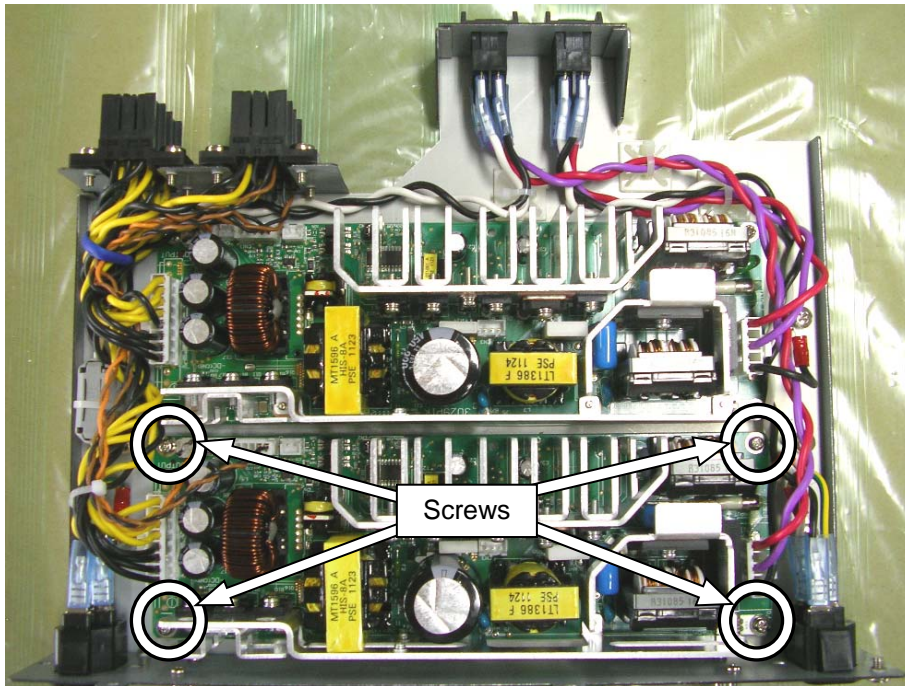

2-3. Connecting Cables

Connect the HVS-100PSM to the switcher using the supplied cables: Cables A, B and C. The completed wiring installation is as shown below.

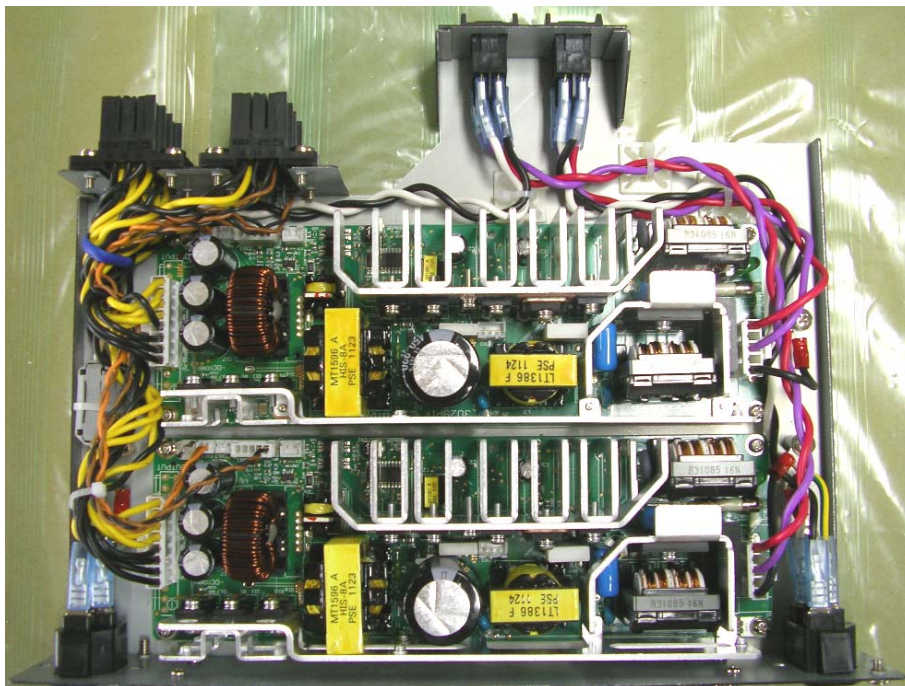

Follow the following instructions to complete the cable installation.

2-3-1. Installing Cable A

- (1) Install the **two black connectors** of **Cable A** by inserting them into the upper holes of the plate as shown below. The connector label should be facing **up**.
- (2) Use the four supplied binding screws (large) to secure both sides of the connectors to the plate.

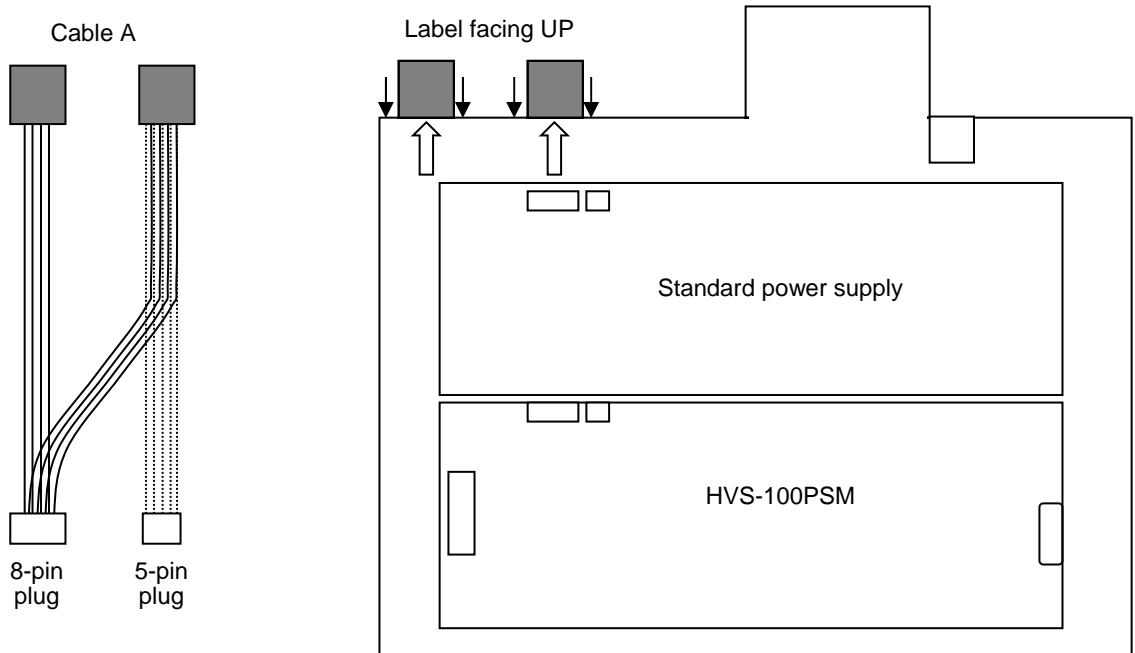

- (3) Connect the **8-pin plug** (white) of Cable A to **Socket a** on the power supply tray as shown below.
- (4) Connect the **5-pin plug** (with black/brown thin wires attached) of Cable A to **Socket b** on the power supply tray as shown below.

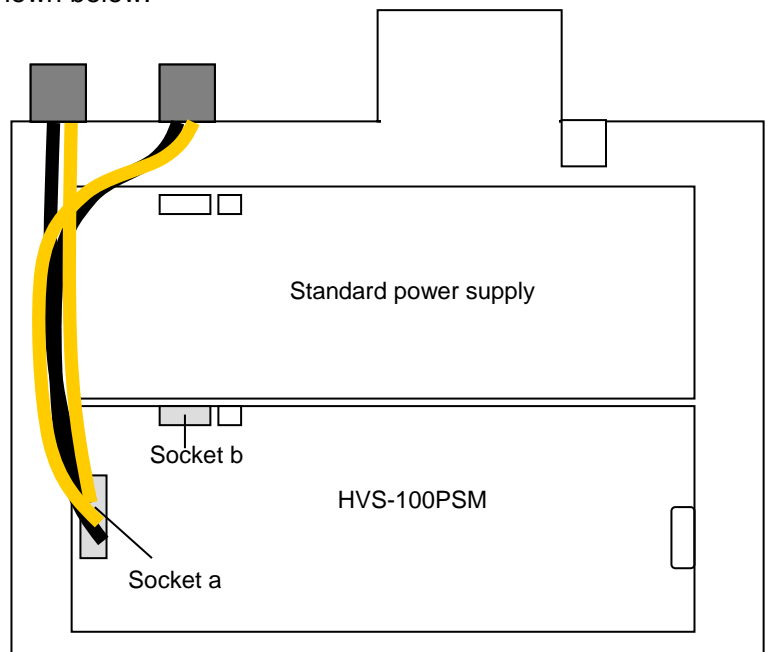

2-3-2. Installing Cable B

Connect **two 2-pin plugs** on both ends of **Cable B** to **Socket c** and **Socket c'** (labeled "CN14" on the board) as shown below. The wiring should be placed beneath the existing cables.

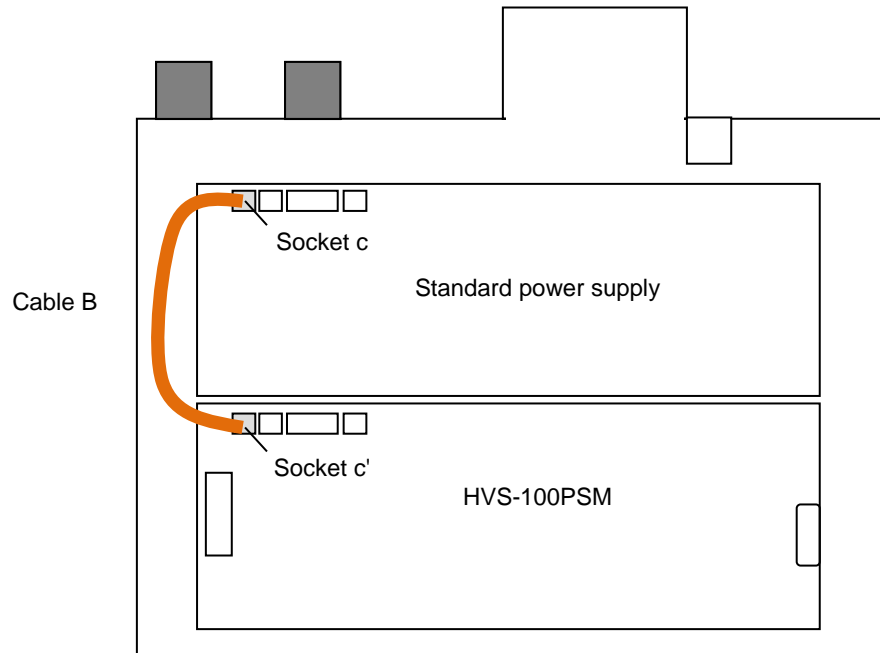

2-3-3. Fixing Cables

- (1) Open the existing **blue cable clip** (shown below) and bundle the cables together, so they do not fall off the tray edge.
- (2) Secure Cable A as shown below with the supplied **orange cable tie**.

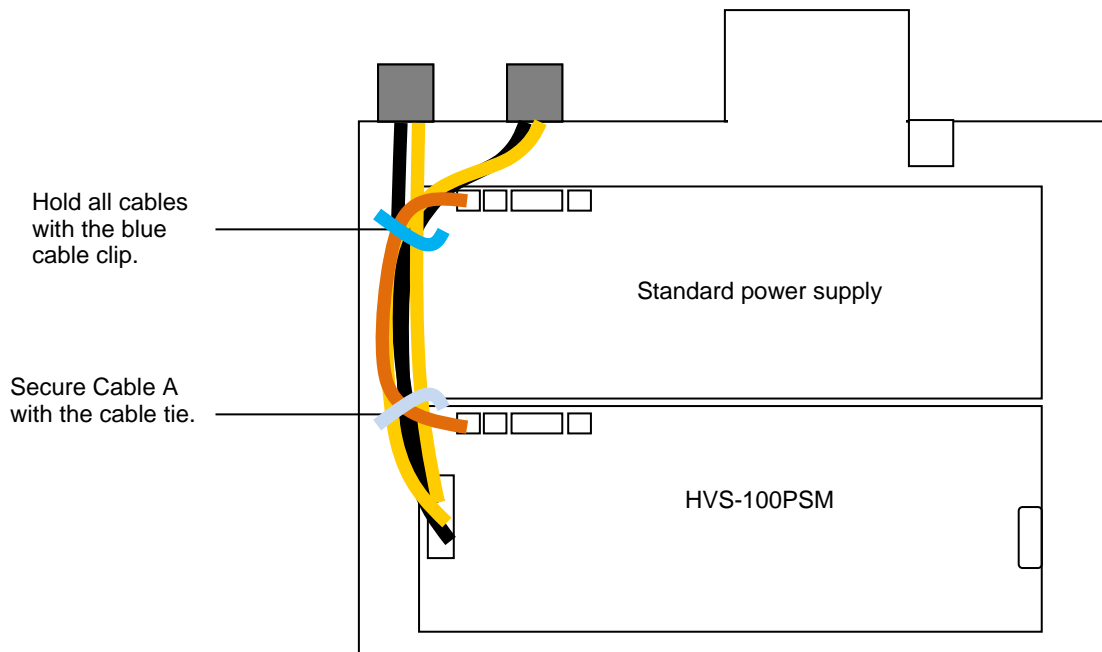

2-3-4. Installing Cable C

- (1) Connect the **5-pin plug** (white) of **Cable C** to **Socket d** on the power supply tray. The wiring should be placed **beneath** the existing cables.
- (2) Secure the **ground cable** of the 5-pin plug to the **hole** of the power supply tray using the supplied **binding screw**, and **normal** and **toothed washers**.
- (3) Connect cables to **Socket f (bottom)** as shown below with the **Violet** cable on the **left**, and **Red** cable on the **right**.
- (4) Secure Cable C with the attached cable tie.

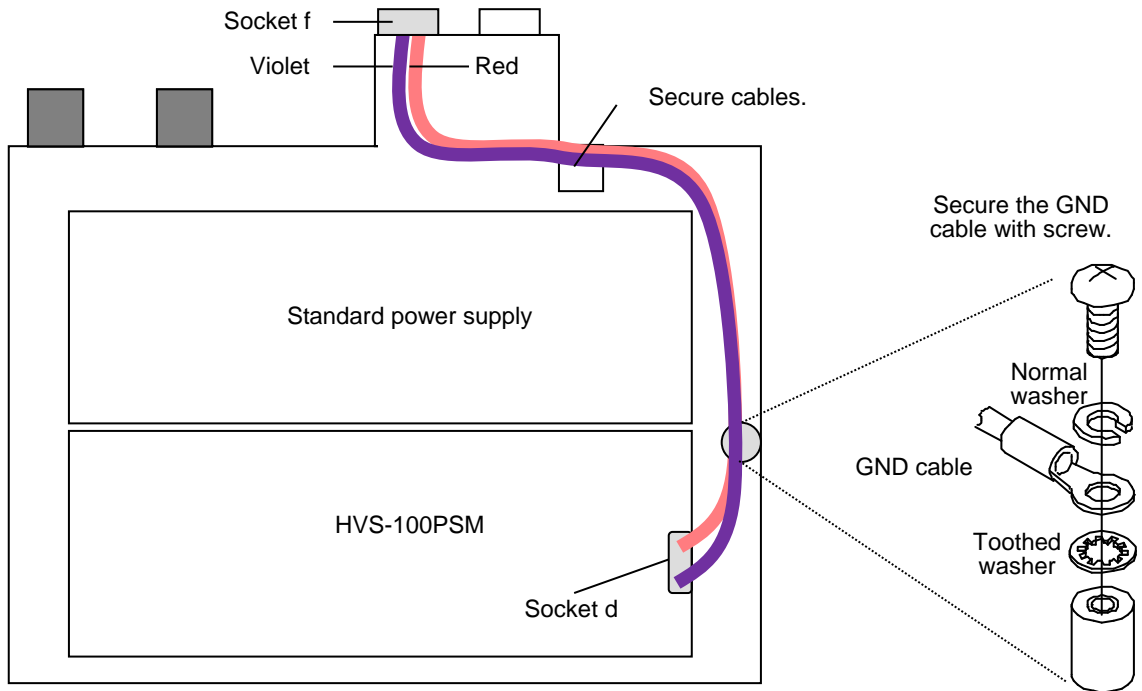

2-4. Re-inserting the Power Supply Tray

- (1) Re-insert the power supply tray in reverse order.

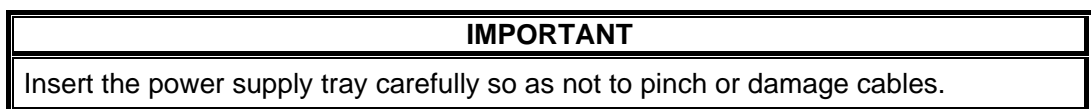

- (2) Secure the power supply tray to the chassis with the four screws removed in section 2-1.

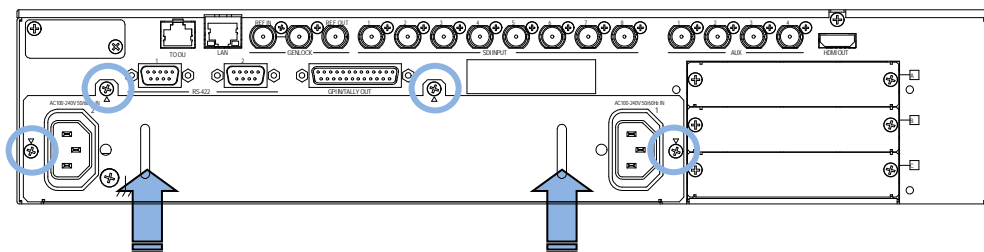

The installation is now complete.

3. Checking Operation

3-1. Power ON

- (1) Connect two power cords to supply power to the switcher. Turn on both power switches.
- (2) Verify that the power indicator on the front panel lights green and the alarm indicator is turned off.

IMPORTANT
The alarm indicator blinks red when an alarm occurs. In such case, power off the system and consult your FOR-A supplier.

3-2. Checking the Status Menu

Follow the procedure below to verify that the HVS-100PSM is properly installed.

- (1) The **MENU** button on the control panel should blink when powered ON.
- (2) Press **MENU**, then press **SETUP**.
- (3) The **SETUP** menu top page appears in the menu display. Turn **F1** to select **STATUS** and then press **F1**.

SETUP	:	>SYSTEM	>INPUT	>OUTPUT	>PANEL
MENU	:	>GPI/TLY	>FUNCTION	>EXT I/F	> STATUS

- (4) The **[SETUP - STATUS]** menu as shown below appears. Turn **F1** to select **ALARM** and then press **F1**.

SETUP	:	> ALARM	>VERSION	>OPTION
STATUS	:			

- (5) The **[SETUP - STATUS - ALARM]** will appear. Verify that "NOR" is displayed for MU PS2 (HVS-100PSM).

STATUS	:	FAN1: NOR	FAN2: NOR	:	1/3
MU ALARM:		PS1: NOR	PS2: NOR	:	

3-3. Affixing the Supplied Label

Affix the supplied label (with serial number) as shown below on the rear panel.

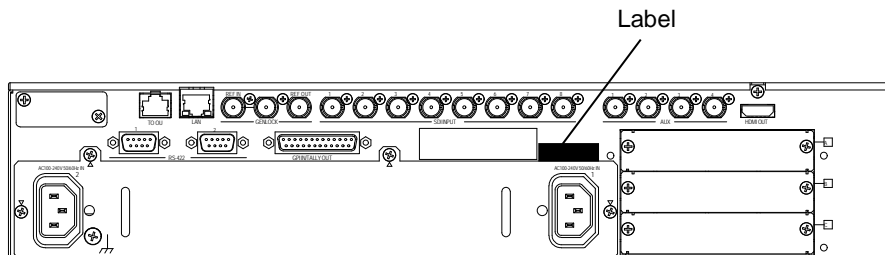

Warning

This equipment has been tested and found to comply with the limits for a Class A digital device, pursuant to Part 15 of FCC Rules. These limits are designed to provide reasonable protection against harmful interference when the equipment is operated in a commercial environment. This equipment generates, uses, and can radiate radio frequency energy and, if not installed and used in accordance with the instruction manual, may cause harmful interference to radio communications. Operation of this equipment in a residential area is likely to cause harmful interference, in which case the user will be required to correct the interference at his own expense.



FOR-A COMPANY LIMITED

Head Office 3-8-1 Ebisu, Shibuya-ku, Tokyo 150-0013, Japan
Overseas Division Tel: +81(0)3-3446-3936 Fax: +81(0)3-3445-5116
Japan Branch Offices Osaka/Okinawa/Fukuoka/Hiroshima/Nagoya/Sendai/Sapporo
R&D/Production Sakura Center/Sapporo Center

FOR-A Corporation of America Corporate Office/Service Center

11155 Knott Ave., Suite G, H & I, Cypress, CA 90630, U.S.A.
Tel: +1 714-894-3311 Fax: +1 714-894-5399

FOR-A Corporation of America Northeast Office

1360 Clifton Ave., Clifton, NJ 07012, U.S.A.
Tel: +1 973-220-8471 Fax: +1 714-894-5399

FOR-A Corporation of America Southeast Office

Tel: +1-305-773-7608

FOR-A Corporation of America Support Center

2400 N.E. Waldo Road, Gainesville, FL 32609, U.S.A.
Tel: +1 352-371-1505 Fax: +1 714-894-5399

FOR-A Latin America and the Caribbean Miami Office

Tel: +1 657-600-5759

FOR-A Latin America and the Caribbean Sao Paulo Office

Tel: +55 (0)11-99913-3751

FOR-A Europe S.r.l.

Via Volturmo, 37, 20861 Brugherio MB, Italy
Tel: +39 039-916-4811 Fax: +39 039-878-140

FOR A UK Limited

Trident Court, 1 Oakcroft Road Chessington, KT9 1BD, U.K.
Tel: +44 (0)20-3044-2935 Fax: +44 (0)20-3044-2936

FOR-A Italia S.r.l.

Via Volturmo, 37, 20861 Brugherio MB, Italy
Tel: +39 039-881-086/103 Fax: +39 039-878-140

FOR-A Corporation of Korea

1007, 57-5, Yangsan-ro, Yeongdeungpo-gu, Seoul 07271, Korea
Tel: +82 (0)2-2637-0761 Fax: +82 (0)2-2637-0760

FOR-A China Limited

1618 Huateng Building, No. 302, 3 District, Jinsong, Chaoyang, Beijing 100021, China
Tel: +86 (0)10-8721-6023 Fax: +86 (0)10-8721-6033

FOR-A Middle East Africa Office

Aurora Tower, Office 1407, Dubai Media City, P.O. Box 502688, Dubai, UAE
Tel: +971 (0)4 551 5830 Fax: +971 (0)4 551 5832

FOR-A India Private Limited. Mumbai Office

2nd Floor, Valecha Chambers, Link Road, Andheri (W), Mumbai 400053, India
Tel : +91-(0)22-2673-3623 Fax : +91-(0)22-2639-3415

FOR-A India Private Limited. Delhi Office

8th floor, World Trade Tower, Sector-16, Noida, Uttar Pradesh 201301, India
Tel: +91-(0)12-0423-8674

FOR-A South East Asia Office

Studio 09, Rm. A1, 3/F., Phase 1, Hang Fung Ind. Bldg., 2G Hok Yuen St., Hung Hom, Hong Kong
Tel : +852 2110-1352